

Model  
**LINEMISS™**

- Convection oven
- Electric
- 4 trays 600x400
- Drop-down door opening
- Control knob

## DESCRIPTION

Combi oven with humidity, analogical control and 304 stainless steel cooking chamber. Time, temperature, steam percentage and 2 fan speeds function. Ideal for all cooking processes of fresh and frozen bakery products. The AIR.Plus technology guarantees perfect cooking uniformity on all baking trays.



## STANDARD COOKING FEATURES

### Manual cooking

- **Temperature:** 80 °C – 260 °C
- Convection and humidity cooking starting from 80 °C

## STANDARD TECHNICAL FEATURES

- Cooking chamber in high-resistance AISI 304 stainless steel with rounded edges
- Double glass
- Cooking chamber lighting through LED lights embedded in the door
- Baking chamber with chrome-plated steel rack rails
- 2-speed fan system and high-performance circular resistance

## ADVANCED AND AUTOMATIC COOKING FEATURES

### Unox Intensive Cooking

- **DRY.Plus:** extracts humidity from the cooking chamber
- **STEAM.Plus:** creates instant humidity starting from 48 °C
- **AIR.Plus:** multiple fans with reverse gear and 2 speed settings

# XFT193

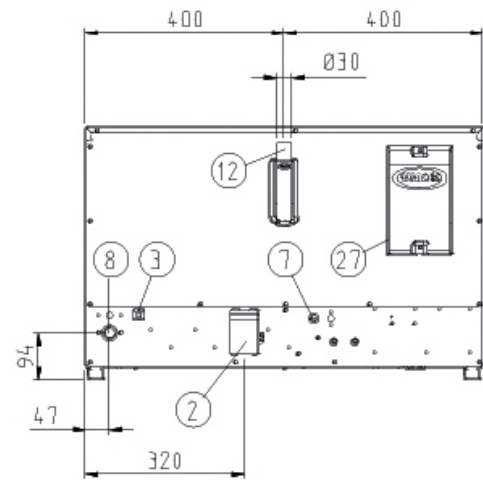
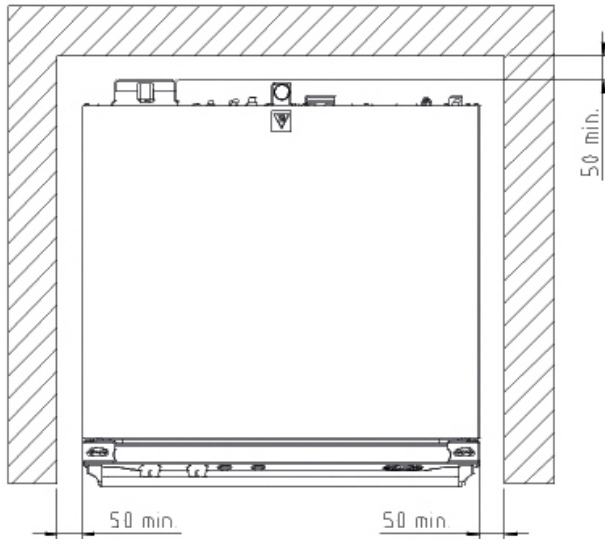
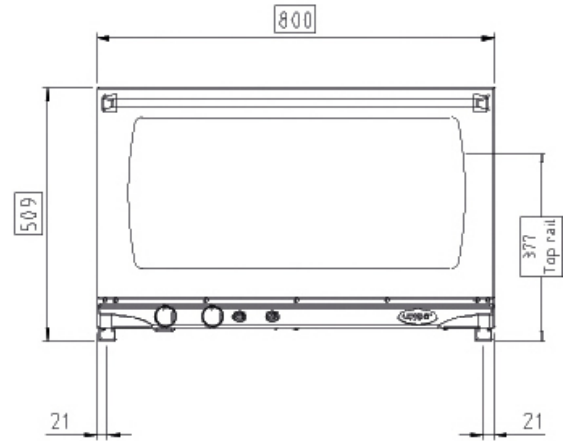
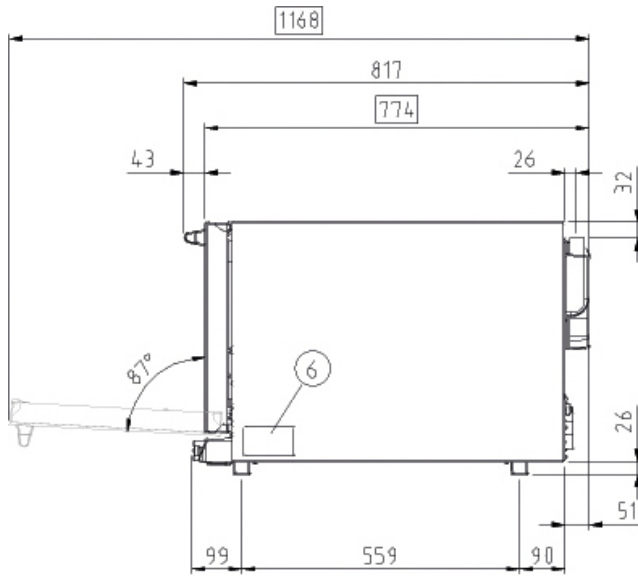

## DIMENSIONS AND WEIGHT

Width	800 mm
Depth	774 mm
Height	509 mm
Net Weight	49 kg
Pan spacing	75 mm

## CONNECTION POSITIONS

2	Terminal board power supply	8	3/4" Thread water inlet
3	Unipotential terminal	12	Hot fumes exhaust chimney
6	Technical data plate	13	Accessories connection
7	Safety thermostat	27	Cooling air outlet

## POWER AND GAS SUPPLY

### STANDARD

Voltage	380-415 V
Phase	~3PH+N+PE
Frequency	50 / 60 Hz
Total power	6,5 kW
Maximum Amp Draw	13 A
Required breaker size	16 A
Power cable requirement	H07RN-F 5G 5G
Cord diameter	16 mm
Plug	NOT INCLUDED

### OPTION A

Voltage	220-240 V
Phase	~3PH+PE
Frequency	50 / 60 Hz
Total power	6,5 kW
Maximum Amp Draw	14 A
Required breaker size	25 A
Power cable requirement	H07RN-F 4G 4G
Cord diameter	16 mm
Plug	NOT INCLUDED

### OPTION B

Voltage	220-240 V
Phase	~1PH+PE
Frequency	50 / 60 Hz
Total power	6,5 kW
Maximum Amp Draw	28 A
Required breaker size	32 A
Power cable requirement	H07RN-F 3G 3G
Cord diameter	16 mm
Plug	NOT INCLUDED

## ACCESSORIES

- **LIEVOX:** equipped with capable sensors to control and intervene automatically on the leavening process
- **Stand:** the multifunctional support ideal for storing trays safely and place your oven at the perfect height to work
- **Baking Essentials:** special trays
- **SPRAY&Rinse:** Practical spray detergent to manually clean all kinds of oven. Degreases and removes all kind of dirt
- **PURE:** the filter reduces the carbonate hardness in water, thus avoiding scale deposits inside the oven cooking chamber

## INSTALLATION REQUIREMENTS

Installations must comply with all local electrical systems, particularly as for minimum wire gauge required for field connection, hydraulic and ventilation supply. Exhaust and fume analysis must be performed in case of gas ovens.

Register to access data and product specifications  
[infonet.unox.com](http://infonet.unox.com)

